

REVISIONS			
ISS	ZONE	DESCRIPTION\PER REQUEST\DATE	
A1	A-7	N6141G1-ATS-1/2A-50 WAS N6141G1-N/NTS-1/2A-50\N/A\10-30-03'	

SALES

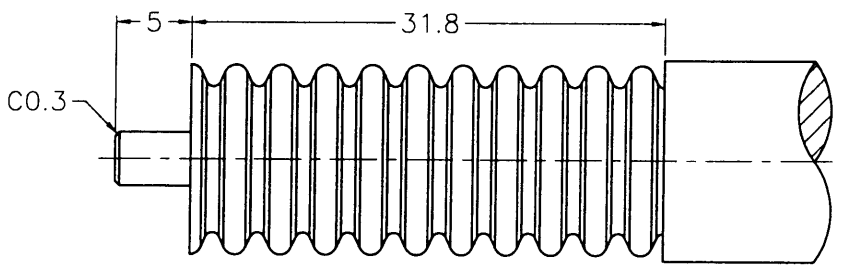

RECOMMENDED
CABLE STRIPPING DIM'S
(建議剝線尺寸)

F
E
D
C
B
A

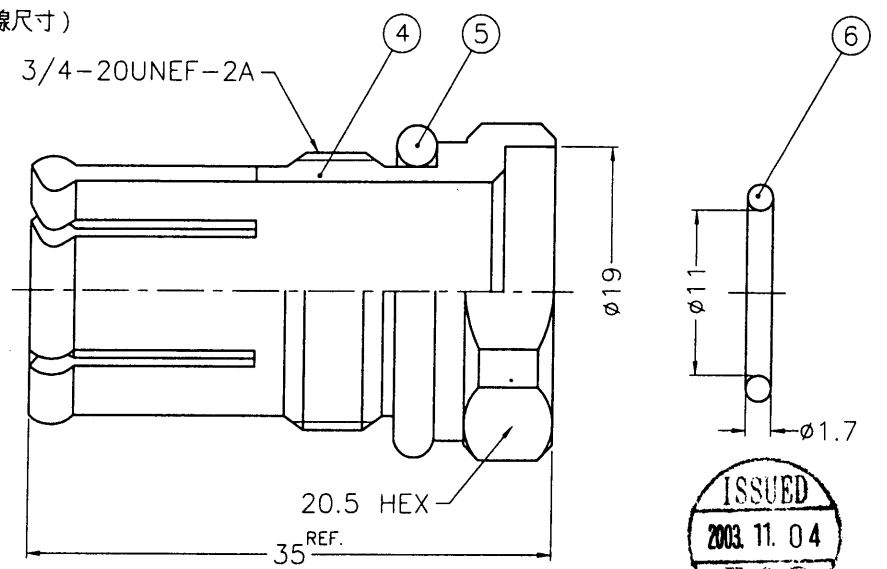
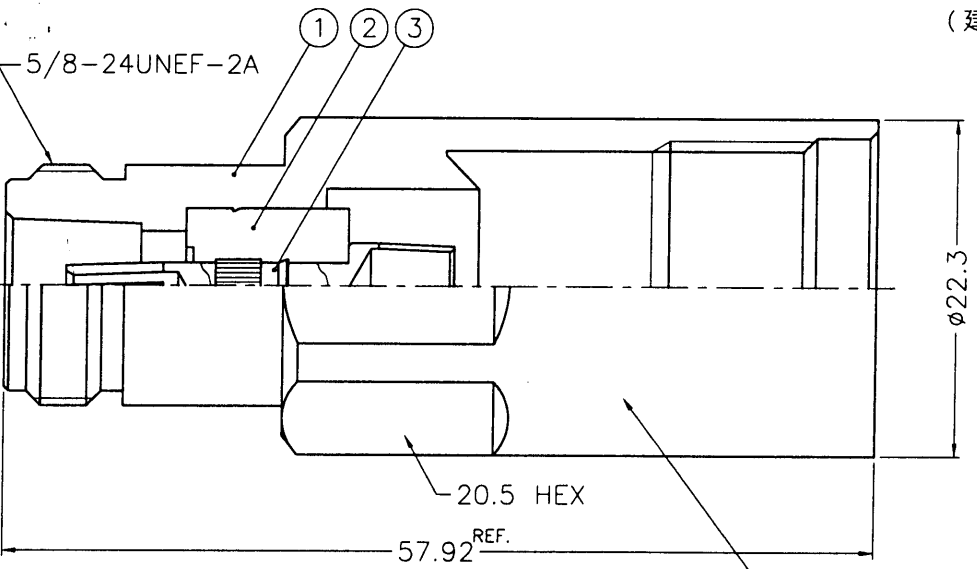

ISSUED
2003.11.04
R&D



- NOTES: FINISH (PLATING THICKNESS IN MICRO-INCHES)
- BRASS PER QQ-B-626
 - ALBALOY PLATING (COPPER-TIN-ZINC)
 - SILVER PL. 200 MIN. THICK OVER COPPER STRIKE
 - TEFLON MIL-P-19468
 - SILICONE GREASE PER POLYTEX 55-M OR EQUIVALENT
 - PHOSPHOR BRONZE PER QQ-B-750

STAMP (IF ANY)
噴字 (若有要求)

NO.	DESCRIPTION	MATERIAL	FINISH	Q'TY	DRAWING NO.
7	LUBRICATOR	NOTE 5	NOTE 5	1	N87070302-11
6	GASKET	SILICONE	RED	1	GS-144/11XD17
5	GASKET	SILICONE	RED	1	GS-21/158XD26
4	NUT	NOTE 1	NOTE 2	1	N87070302-7
3	CONTACT PIN	NOTE 6	NOTE 3	1	N6141G1-3-1/2A
2	INSULATOR	NOTE 4	NATURAL	1	N87070302-3
1	BODY	NOTE 1	NOTE 2	1	N6141G1-1-1/2A

DIMENSIONS ARE IN MILLIMETERS			
UNLESS OTHERWISE SPECIFIED TOLERANCES			
0.5-6	=	±0.2	
6-30	=	±0.4	
30-120	=	±0.6	
120-315	=	±1	
315-1000	=	±1.6	
1000-2000	=	±2.4	

PART NO.	
APPROVED	DATE
CHECKED	DATE
DRAWN	DATE
FILE NO.	F:\DWG\N\6141G1\12A-50\ATS-A1

Amphenol	
Danbury,CT,USA-Tainan,Taiwan-Shenzhen,China	
TITLE	N CLAMP JACK (FOR ANDREW 1/2" LDF4-50A HELIAX CABLE)
DRAWING NO.	N6141G1-ATS-1/2A-50
ITEM NO.	036141AAHA1AB5F

A